

CFD Simulation of Corium / Materials Interaction for Severe Accidents

B. Farges¹, N. Goreaud¹

¹AREVA NP, F-69456, Lyon, France

E-mail contact of main author: benjamin.farges@areva.com

Abstract. In case of a severe accident inside a sodium-cooled fast reactor, corium interacts with many materials along its way towards the core catcher. Once deposited, corium can also interact with protective and / or sacrificial material. Among those materials, refractory ceramics like zirconia are credible candidates due to their high fusion temperature. Through CFD methodology, calculations have been made in order to reproduce the fusion mechanism and kinetics of the $\text{UO}_2\text{-ZrO}_2$ system, in order to reproduce ablation phenomena of ZrO_2 by UO_2 . This process is not only thermal but also chemical, as eutectic material formation is expected, around 2500°C . That is why the eutectic diagram of the $\text{UO}_2\text{-ZrO}_2$ system has been linearized and put directly inside the CFD software in order to take into account the formation of this eutectic material. Comparisons have been made with experimental data: a layer of UO_2 is deposited inside a cooled zirconia crucible. Results show good correspondence between calculated and experimental data: the onset and effective melting of the zirconia is modelled, but also chemical saturation processes are identified, explaining the inhibition of the melting after a certain time. This opens the way for more complex calculations.

Another application of this methodology is used in the frame of In-Vessel Retention purposes. A CFD simulation is made modelling the progression of the melting front inside the thickness of the bottom of a steel vessel due to the presence of molten UO_2 emitting residual thermal power. Results show the formation of a floating steel layer at the surface of the UO_2 molten pool, and the consecutive focusing effect occurring on the solid remaining parts of the steel vessel. These calculations show that some of the complex thermo-chemical phenomena occurring during a severe accident can be modelled and used in order to give better understanding of the main phenomena.

Key Words: Severe accidents, corium, CFD, multiphase.

1. Introduction and context

The purpose of this paper is to show the possibilities of corium erosion CFD modelling, which can be interesting for core-catcher or in-vessel retention issues for next generation nuclear reactors (such as sodium-cooled fast reactors). Though some experimentation data exists in the literature, CFD modelling can provide a good alternative in predicting such interactions and their consequences.

This paper first focuses on the $\text{ZrO}_2 - \text{UO}_2$ melt interaction, as ZrO_2 is a refractory ceramic, which is an interesting candidate for potential protection of an inner core catcher concept. Furthermore, there is a history concerning the use of ZrO_2 in PWR studies involving corium migration calculations towards a core catcher. Other interactions are treated such as steel- UO_2 for in-vessel retention purposes. Indeed, modelling the melting front inside the thickness of the bottom of a steel vessel and the associated phenomena is of interest in case of the failure of corium retention inside an inner core catcher for instance.

These two situations need distinct means of modelling, since a $\text{ZrO}_2 - \text{UO}_2$ can form a eutectic material, whereas steel and UO_2 do not mix and tend to segregate. As a result, distinct methodologies are presented for each situation. When available, experimental data is used for comparison with modelling results, which provides a first set of validation elements.

2. Thermal ablation of ZrO_2 by UO_2 and modelling of the formation of eutectic material

a. $UO_2 - ZrO_2$ phase diagram

The quasi-binary phase diagram of the $ZrO_2 - UO_2$ system is considered in the frame of this paper only for a high range of temperature (from 2750 K and onwards). Indeed, as only severe accident conditions are to be studied, only a certain range of temperature is of interest. As FIG. 1 shows, the upper part of the $ZrO_2 - UO_2$ phase diagram is notable for its recognizable eutectic shape. Eutectic material formation at high temperatures is strategic for severe accident mitigation purposes, as ZrO_2 can help long-term stabilization of molten UO_2 as well as neutronic dilution and global cooling, by forming a chemically stable mixture with it.

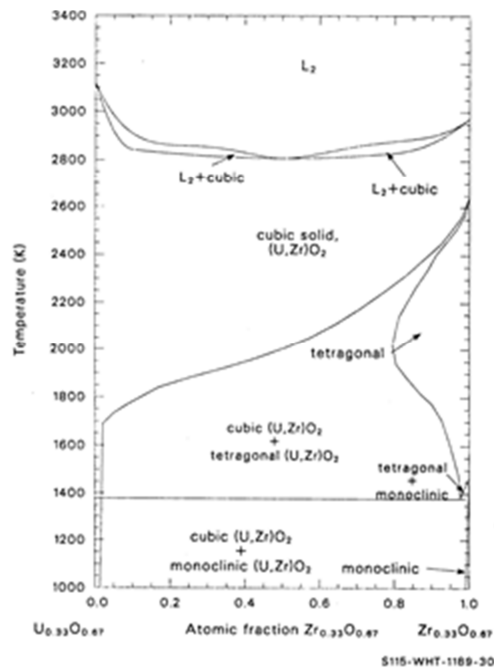

FIG. 1. Phase diagram of the $ZrO_2 - UO_2$ system (from ref. [1])

b. Experimental setup

Some laboratory tests were done on the interaction of ZrO_2 material with corium melts in the frame of the CIRMAT (Corium Interaction With Refractory Materials) program. These tests took place in the experimental facility RASPLAV-2 in Germany for the CIT (Corium Interactions and Thermochemistry) project. These experiments were made using a “cold-crucible” technique: a $UO_2 - ZrO_2$ melt is generated in a crucible furnace by high-frequency induction heating and cooled on the side by water tubes. The melt is put into the crucible, above a layer of ZrO_2 ceramic (see FIG. 2). The main purpose of these experiments was to assess the ablation rate of a zirconia sample by a corium melt. This ablation velocity was eventually measured and plotted.

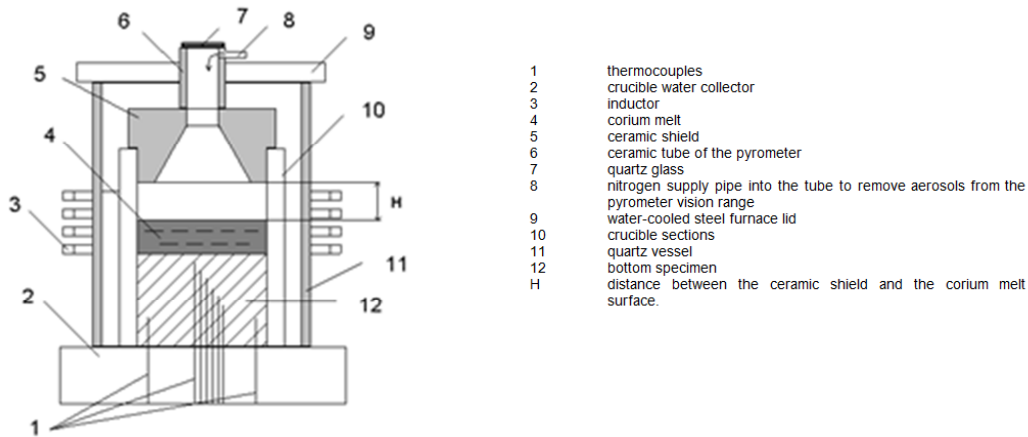

FIG. 2 . Setup of the CIRMAT experiment

At the end of the test, zirconia ceramic samples are removed from the crucible and cut in half. FIG. 3 shows the appearance of the ceramic sample after the interaction with molten UO_2 .

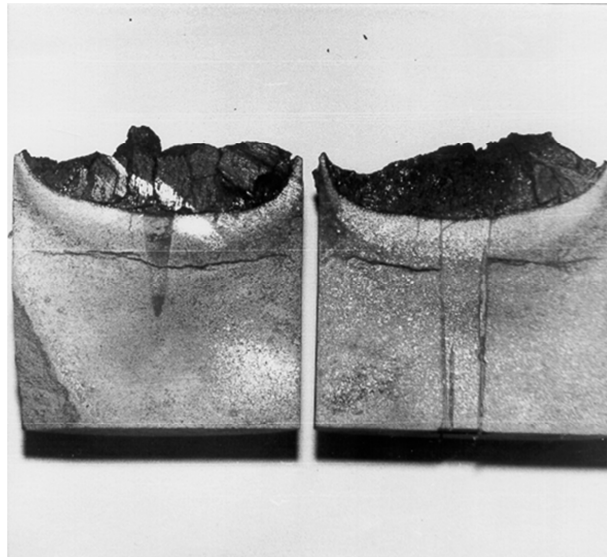

FIG. 3 . Cut of the ceramic sample at the end of the experiment

c. Numerical setup and boundary conditions

The software used in order to model the ablation phenomenon is Ansys Fluent v15.0. The numerical setup uses the melting / solidification model (which is an enthalpy / porosity approach), and the species transport model. Ansys Fluent also allows the user to manually enter the phase diagram into the computation. The model is transient and was run for a duration similar to the one of the experiment. The non-iterative time advancement (NITA) solver was used for faster computations and the time step is set to 0.01 s.

A cell-size of 0.5 mm has been chosen. In order to minimize computation time, a 2D-axisymmetric model and meshing has been carried out, since the experimental geometry is of cylindrical nature. As seen in FIG. 4, the boundary conditions are set in order to reproduce the experimental setup as regards the inner power carried by the corium melt as well as the cooling effect of the water tubes.

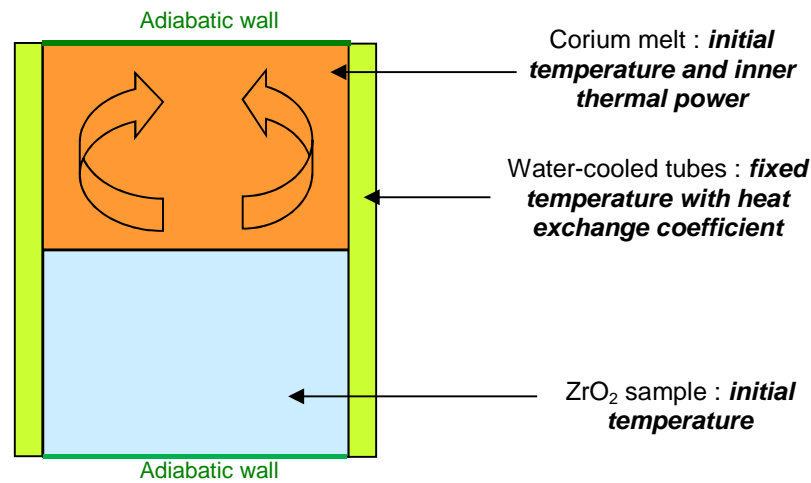

FIG. 4. Boundary conditions of the CIRMAT experiment numerical simulation

The 2D-axisymmetric mesh was made of approximately 15 000 hexahedral cells. The domain is defined as a mixture of the two species: UO_2 and ZrO_2 whose initial mass composition is:

- the corium composition of the experiment in the “corium zone”,
- 100% ZrO_2 in the “ceramic zone”.

The density is the volume average of the density of each material. Viscosity, specific heat and thermal conduction are the mass-weighted average of each material.

No turbulence model was used in these calculations since this problem is laminar; the maximum value of the Reynolds number is always less than 3000 (mostly because of the UO_2 viscosity and the small dimensions of the experimental setup).

d. Solidification and melting settings

To define a phase diagram on Fluent, it is necessary to specify a solvent, which is supposed to be the majority species material. Indeed, Fluent only works on one side of the phase-diagram, from the melting temperature up to the eutectic temperature. In this case, the solvent is ZrO_2 and the solute (the minority species) is UO_2 .

Defining the phase diagram in Fluent can be done with several parameters, which have to be specified for the solute and not for the solvent:

- The slope of the liquidus line : the input parameter has to be a negative value, otherwise the slope is calculated with the melting temperature, the eutectic temperature and the eutectic mass fraction
- The partition coefficient
- The melt temperature
- The eutectic mass fraction

For more complex phase diagrams as the quasi-binary $\text{UO}_2 - \text{ZrO}_2$ phase diagram, liquidus and solidus temperature can be defined through user-defined functions. However, the solid-liquid interface temperature still depends on the above parameters.

e. Results and analysis

Once the $\text{UO}_2 - \text{ZrO}_2$ melt is deposited on the ZrO_2 surface, it starts to ablate the ceramic sample. Inside the liquid phase, convective movements establish. As *FIG. 5* shows, the ceramic is slowly ablated by the corium phase, and the liquid phase grows with eutectic molten material formation. After 600 s, the ablation slowly decreases and finally stops.

As regards ceramic ablation values over time, results show good agreement with experimental data, given the error margins, as *FIG. 6* shows. The first part of the curve is quasi-linear but quickly the ablation slows down and tends to an asymptotic value. This may be explained by melt saturation in ZrO_2 at the melting front. Another explanation, which was proposed by experimentalists, was the change of high-frequency power due to electromagnetic and geometric effects. These effects are not modeled and it could explain the slight slope differences between numerical and experimental curves.

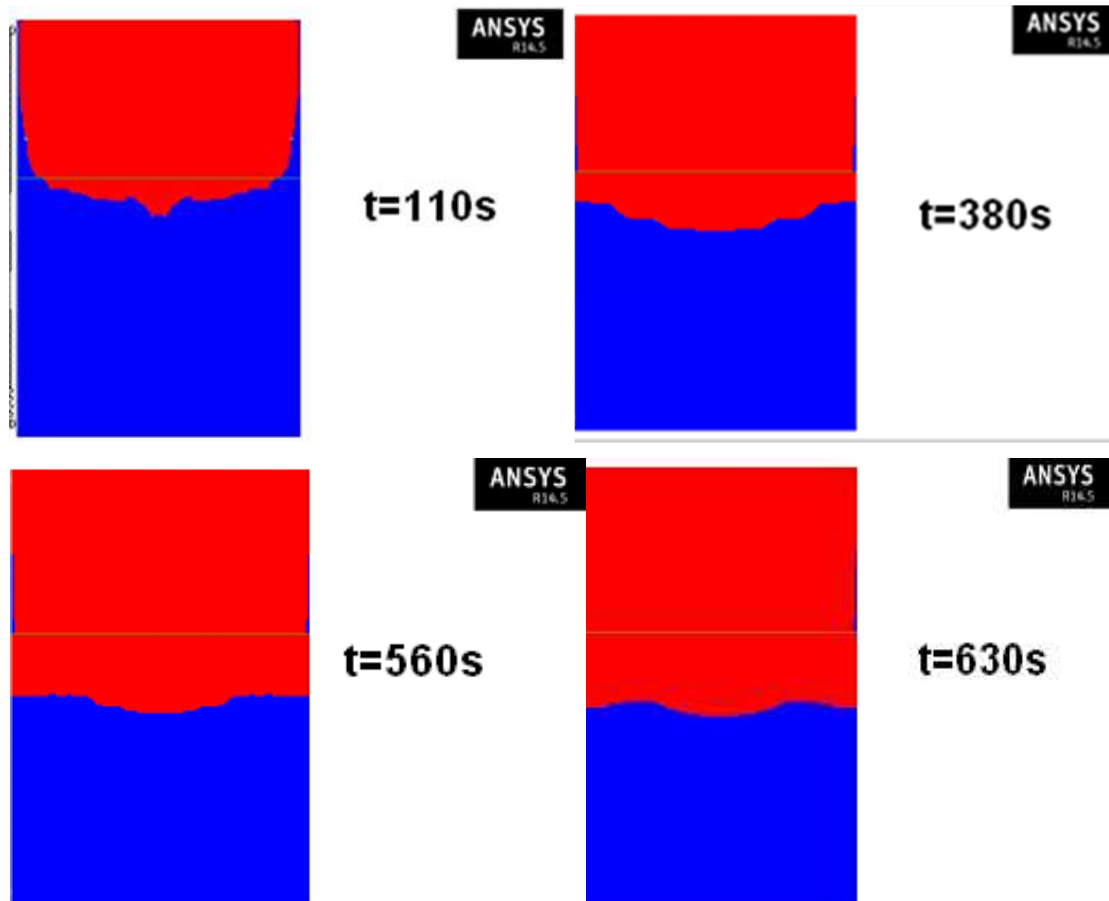

FIG. 5 . Evolution of the liquid fraction from 0s to 630s after ZrO_2 crucible beginning of melt

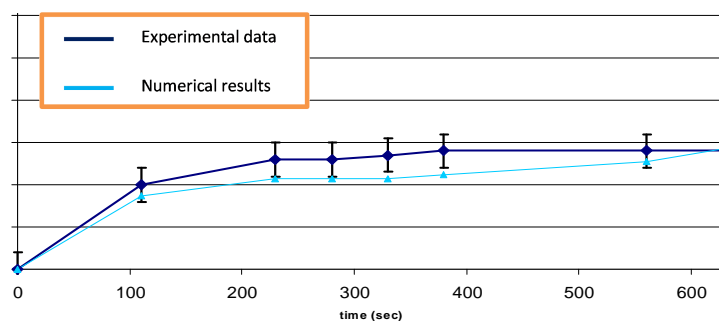

FIG. 6. Evolution of the ablation depth of ZrO_2 : experimental data vs. numerical results

3. Modelling of In-Vessel Retention (IVR)

Another application for multispecies CFD modelling in the frame of severe accidents is the assessment of in-vessel retention (IVR) capability of a given reactor geometry.

The interaction between corium and steel has been widely studied from a chemical point of view: a lot of relevant phase diagrams can be found in [2]. Some references can also be found that take into account the hydraulic aspects. See for example [3] and [4]. The conclusion of this bibliographic review is that since the different materials are immiscible in liquid phase, thermochemical aspects can be neglected at first order and focus can be made about the thermal effects, considering that each material occupies a different phase.

As a result, in contrary to what has been studied previously in this paper in the case of the $UO_2 - ZrO_2$ system, steel and UO_2 must be studied in a multiphasic approach.

Following this assumption a first numerical study was conducted. The simulation was performed on a reduced model (scale 1/100) of a spherical bottom of a reactor main vessel. The corium volume is evaluated considering a total melting of the nuclear fuel in the core.

The focusing effect consists in a high ratio between lateral heat fluxes and bottom inlet heat fluxes.

The main hypothesis for IVR is the arrival of corium on the bottom of the vessel. The steel from the vessel melts when the corium arrives, due to its high temperature, leading to a layer inversion. Indeed, liquid steel, less dense than corium, rises up to the surface whereas the corium keeps ablating solid steel. Since the conductivity of steel is much higher than the conductivity of corium, thermal fluxes will be higher at the free surface. This means that lateral fluxes will be higher than downward fluxes. Therefore, the ablation depth will be higher on the sides of the vessel.

The main chronology can be summarized as follows:

- corium arrival on solid steel,
- melting of solid steel,
- migration of liquid steel on top of the corium due to density differences,
- lateral ablation of the main vessel due to the high conductivity of liquid steel: this is the focusing effect.

a. Modelling setup and boundary conditions

The main goal of this simulation is to observe, in a simplified 2D-axisymmetric calculation case, the main physical phenomena expected to occur in this situation. FIG. 7 shows how the boundary conditions are set in the model. Full predictability is not yet a priority, as several parameters need to be studied further.

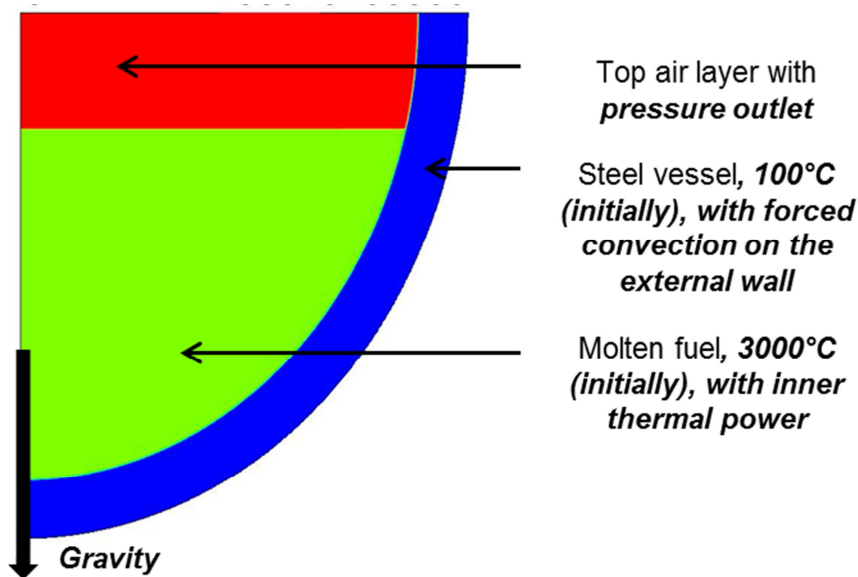

FIG. 7. Boundary conditions of the numerical simulation of IVR

The corium zone is meshed with an unstructured triangular mesh, and the steel zone with hexahedral cells. As the modelling of phase change and multiphase non-miscible fluids requires small cell size, the base cell size is 0.1 mm. The total mesh size is about 500 000 cells. Boundary conditions take into account :

- The decreasing of the residual power over time (as molten fuel is assumed sub-critical),
- The cooling on the external part of the main vessel by emergency water supply,
- A gaseous layer on top of the corium pool which absorbs free surface disturbances.

The simulation is transient with a time step of 0.0001 s. The numerical coupling scheme used was the SIMPLE algorithm, with second order discretization schemes for momentum and energy, and PRESTO! Algorithm for the pressure. The IVR flow is modelled as a multiphase flow using the VOF (Volume Of Fluid) model. Indeed, since the fluids are non-miscible, the challenge is to track the interface between the phases, which makes VOF a natural choice.

b. Results and analysis

Transient calculation has been run until focusing effect observation. From a descriptive point of view, the IVR chronology can be described as a sequence of three main phases.

- an early phase where the temperature in the corium pool increases due to the residual power, where the natural convection develops until the first steel parts are melted and start to buoy to the top of the corium pool ;
- a second phase where the steel is ablated and a liquid steel layer forms at the top of the corium pool.
- a third and last phase where the liquid steel layer is fully developed and the ablation starts to be predominant on the side of the vessel.

The three phases are illustrated on *FIG. 8* below. The phases repartition is shown and the steel ablation and relocation is visible.

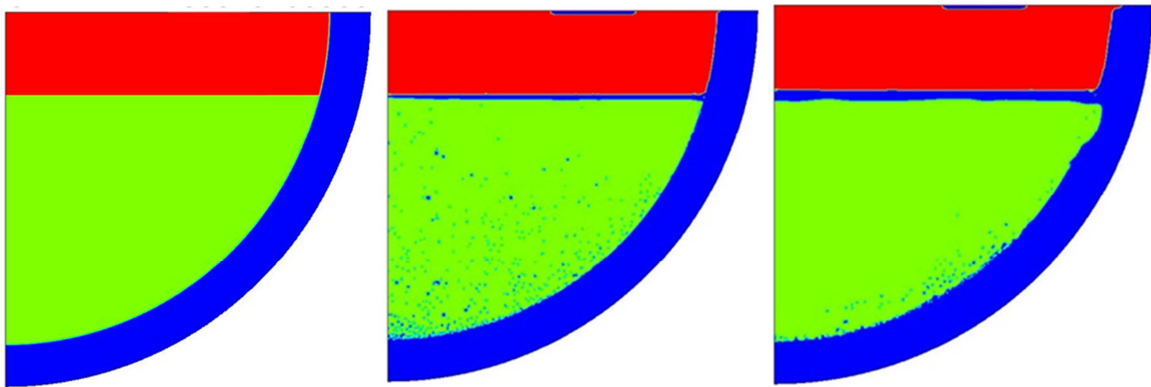

FIG. 8 . IVR simulation - Evolution of the phase fraction (green : liquid / blue : solid / red : gas)

Predictably, the main vessel steel melts in contact of the UO_2 melt and steel bubbles form. Those bubbles rise up to the free surface and aggregate until they form a liquid steel layer on top of the UO_2 pool. Finally, this steel layer conveys a strong thermal flux towards the side of the steel vessel, which melts locally much faster. The temperature field shown on *FIG. 9* also illustrates the mechanism responsible for steel vessel ablation, as well as the stratification inside the corium pool.

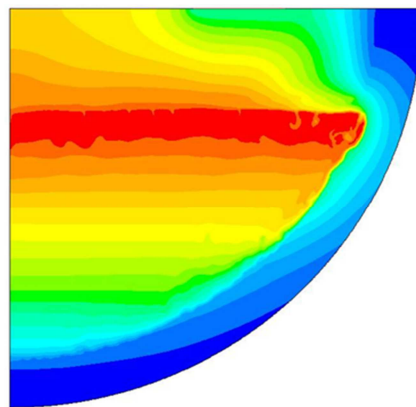

FIG. 9 . IVR simulation – Temperature field at the end of the simulation

4. Conclusion

Use of multiphasic and/or multispecies CFD modelling in the frame of fast reactors design, and especially severe accidents phenomena understanding, can provide useful insight for such situations.

Two applications have been presented, both of them using Ansys – Fluent as a CFD software :

- Regarding the use of refractory ceramics in severe accident management, the ZrO_2 – UO_2 system has been integrated into the methodology. Comparison has been made between numerical and experimental results in the frame of an ablation experiment and showed good accuracy. Such a methodology can be reproduced with other ceramics compatible with UO_2 such as Al_2O_3 for instance.
- Regarding the in-vessel retention issue, a numerical test case has been made, and was able to reproduce the main expected phenomena as well as the onset of the focusing effect, responsible for the main vessel thermal ablation. Though simplified, such a simulation opens the way for more complex applications and possible long-term predictability.

References

- [1] J.K. Fink
Thermophysical properties of uranium dioxide
Journal of Nuclear Materials 279 (2000) 1-18.
- [2] V.I. Almjashhev *et al.*
Phase equilibria in the FeO_{1+x}-UO₂-ZrO₂ system in the FeO_{1+x}-enriched domain
Journal of Nuclear Materials 400 (2010) 119-126
- [3] O. Kymäläinen, H. Tuomisto, T. G. Theofanous
In-vessel retention of corium at the Loviisa plant
Nuclear Engineering and Design Volume 169, Issues 1-3, 1 June 1997, Pages 109-130.
- [4] J-M Bonnet, J-M Seiler, CEA Grenoble (1999)
Thermal Hydraulic phenomena in corium pools: the Bali experiment. 7th international conference on nuclear engineering, Tokyo..